

Building our Climax - Plan and Report

Paradise Valley Railroad, Powell River BC

As of Jan 5, 2026

Climax 2-truck locomotive. At 2.25" scale

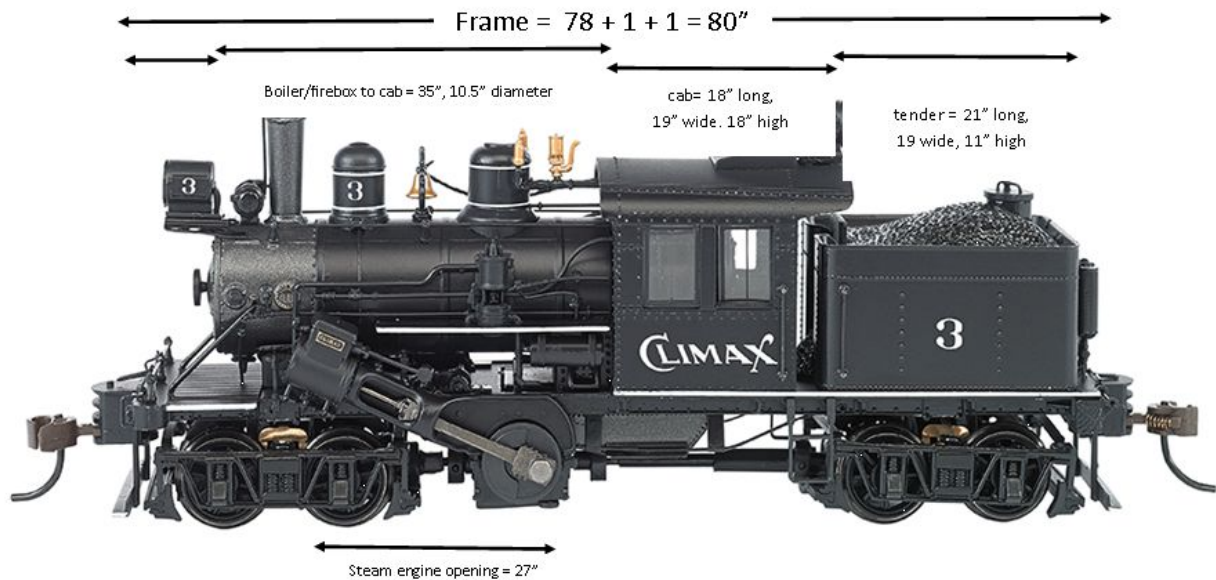

- we are basing our model on several sources:

- the above photo of a small scale Climax. E.g., We'll likely use the straight boiler rather than the tapered one in Kozo's plan; and

- the Kozo Hiraoka Climax book which describes a 3/4' scale model.

Our nominal dimensions are 3x of the 3/4" Kozo plans to make ours a 2.25" = 12" model. On our 7.5" tracks it becomes a Narrow Gauge model.

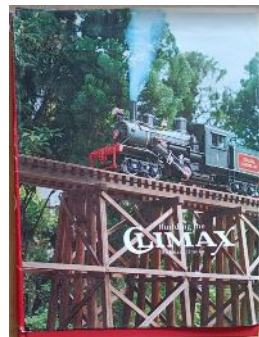

- Dimensions will be adjusted to fit available material.

- We're not doing the skew-bevel gearing and drive shaft; (ie, we're after a Climax-like silhouette rather than an exact model). We're simply using two arch bar trucks with 5.5" wheels (by Tom Artzberger). (Wheels on this actual Climax were 33", or 6.2" at our scale. wheels (would be 29.3" actual, more like freight car sized).)

Follow-on Pages:

Trucks, Frame, Cab, Boiler, Engines, Coal/Water tender,
Follow-on Braked Operator/Passenger Car,
Controller, Batteries, Compressor, Sound Card



Figure 1: Geoff's G-Scale Climax

Trucks

The Climax trucks are currently under Little Toot; we need to get three new motors to restore Little Toot with its original trucks



- Bought from Tom Artzberger.

Dave Florence picked them up and returned to PR March 2024.

Trucks are 14.5 wide, 20” long and 6” high

Eight 24 volt Motors at 7.55 amps max = 0.18 hp each; = 1.5 hp total, torque for each =75 in. Oz



Dan spoke with Tom Artzberger and made the connector fit the bolster.

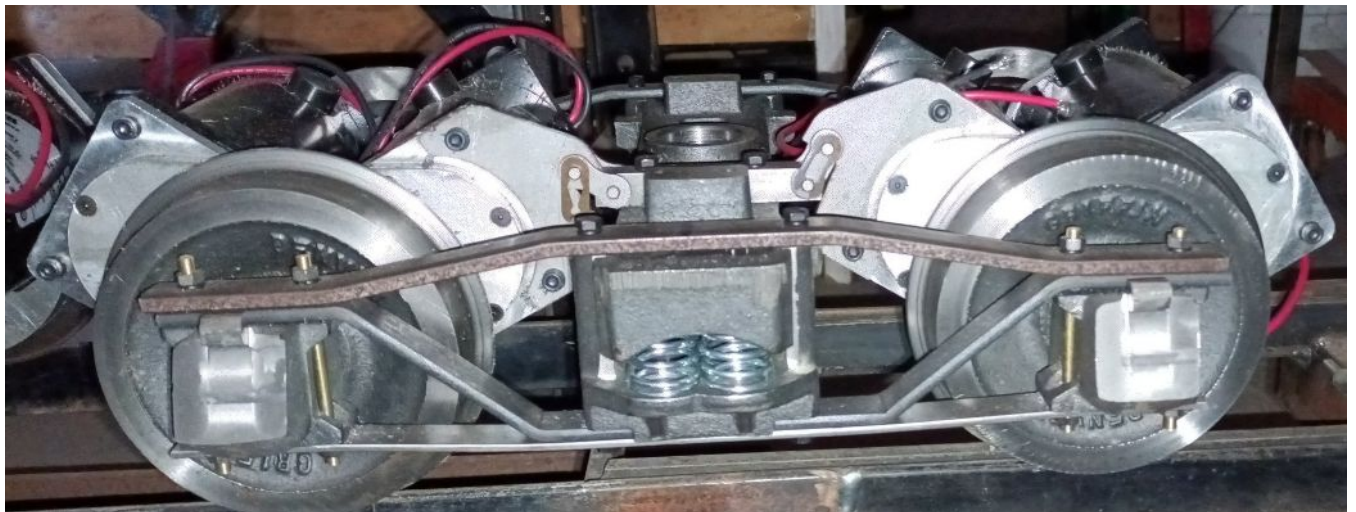

2 / 12 PVR C



Frame, Bolsters and 3" Brackets

The frame is mainly completed – above photos not current as of Jan 5 2026

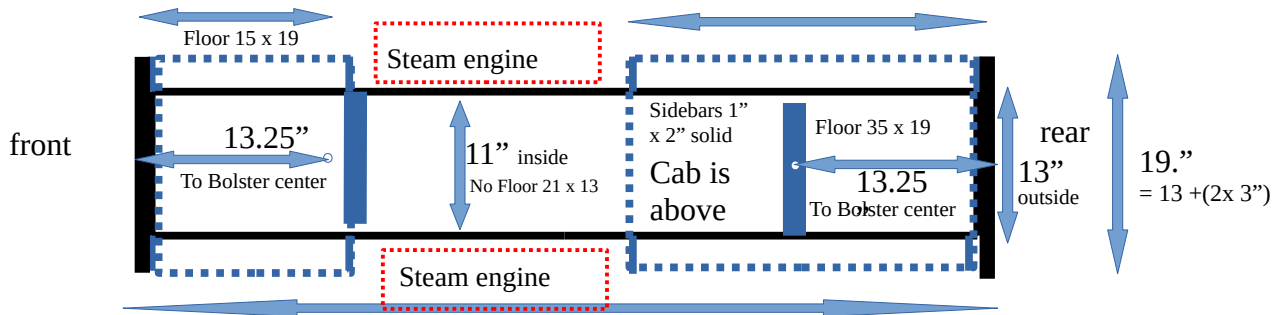

71" sidebar 1x2 solid, two 1" x 4" bumpers, 1.5" foot board at front and connector to pax car = 76"
 total - The 2 bolsters are 3/4"x2.5" steel donated by Dan
 - The 8 Brackets to extend the flooring wider are 3/4 x 2 x 3" steel

The frame is a simple rectangle 13" wide with 3" supports at eight places each side for the floor plates (dotted line) that hang over the edge under the coal bin, cab, boiler etc, making it 19" wide. Bolster centres are 13.25" in from each end. Bumper bar and other bits hang off the ends making total length 71 The bolt hole in the centre of the bolsters is 3/4"

A floor is put on the frame under the water/coal bin, cab and part of the boiler, plus at the front, but omitted where the steam engine is outside the frame.

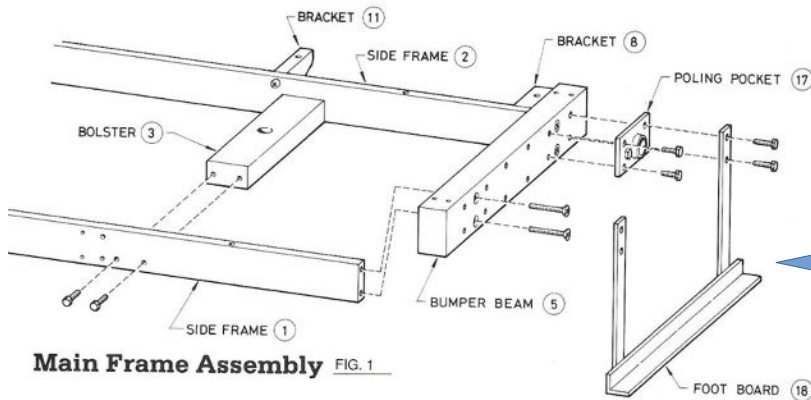

Bumper Beams and Bolsters are from a 1x4" steel piece that Dan is donating. Foot board are not yet designed



CAB

Until we build our own, Dan has offered us to use one of his cabs temporarily.

Cab is now planned, ready for sheet-metal fabrication, hopefully led by Andre Dalcourt .. Jan 5, 2026

Dan's cab is 18" wide, 22" high, 14" long

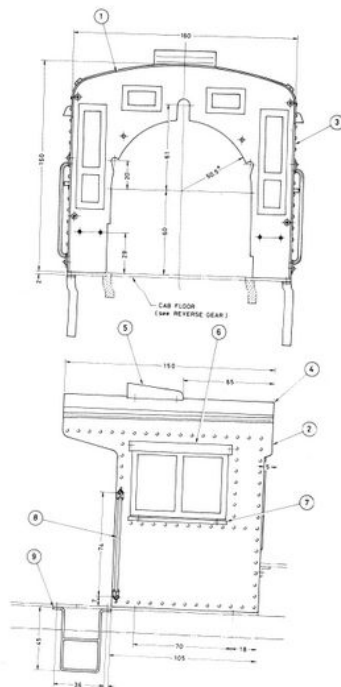

Our cab is 19" high and 18.4" wide (1/4" in from the full 19" width)

Dan plans to complete the measurements and contract out the sheet metal needed.

Engines

The prototype engine is on-site, ready for a project leader to build the second one and perhaps finish the first with metal parts – Jan 5, 2026



The defining feature of a Climax is the slanted engines, 22 degrees.

The idea is to have one on each side on a trans axel and power them with a small motor synchronized to the drive motors.

Dave built a model from wood and stovepipe metal. We need to complete the model, duplicate the mirror image, attach them to a trans-axel, and motorize the axel.

11 Engine

The engine of the Climax has a similar construction to that of the conventional rod locomotive, except that the cylinders are inclined at about twenty degrees. The elevation and top view in the assembly drawing show the right side assembly, the left side being opposite-handed.

In general, older Climax locos were equipped with Stephenson-type valve gear, and later ones with Walschaerts. As you see in the drawing, this Climax is designed with Walschaerts valve gear whose movements are more interesting to see. Each of the right and left engine

assemblies is bolted on the Main Frame and the Crankshaft Frame. Material of the Cylinders (1) and (2) is copper-tin bronze, and the Pistons (14) are made of phosphor bronze. The groove in the Piston

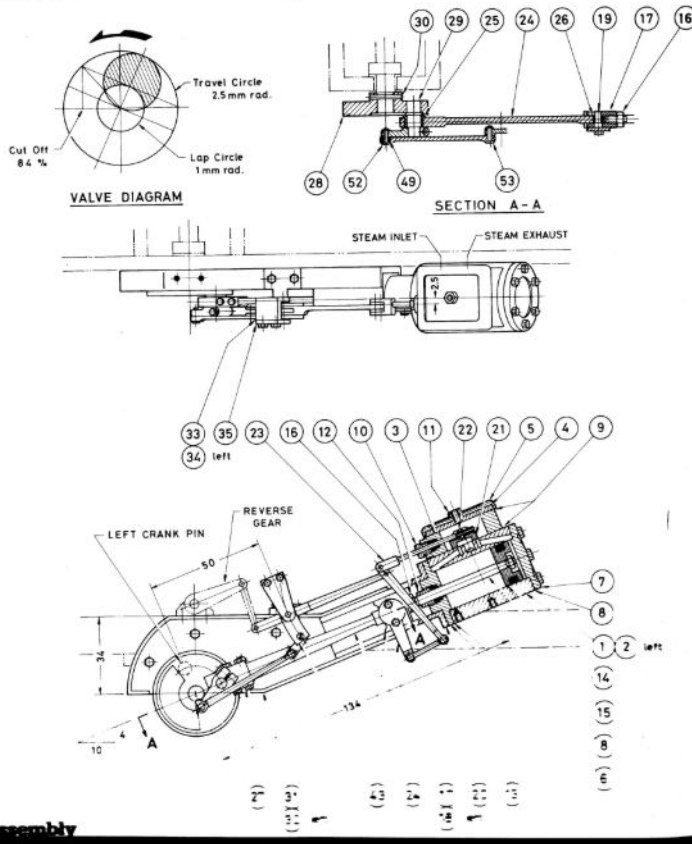

Coal/Water Tender

Built and in place, ready for detailing – Jan 5, 2026

21” long, 18.5” wide and 11” high

Space in side can be used for a child seat
(not big enough for an operator seat (see Kozo drawing below))

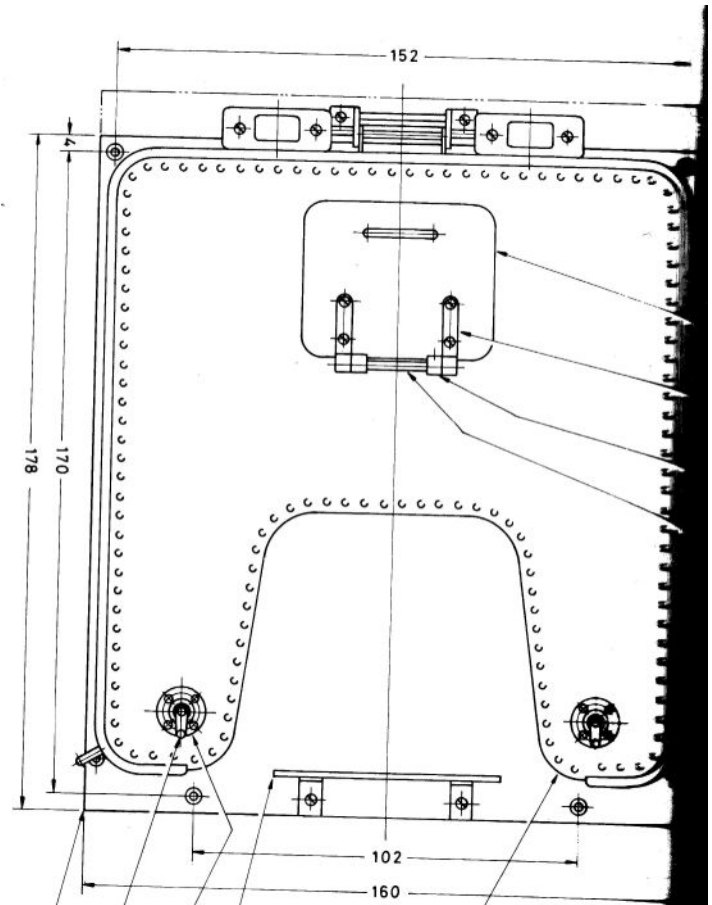
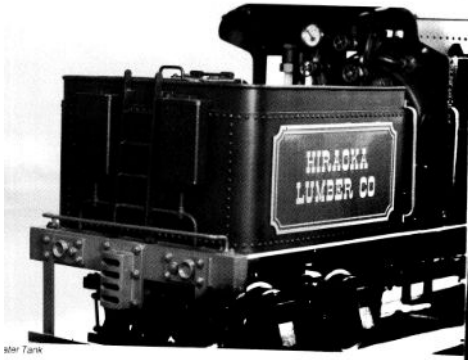

Follow on car

The idea is to combine a passenger car with the engineer's position.

We bought two new air-braked trucks from Tom Artzberger so the Climax can have a brake-equipped car immediately behind.

The front of the car where the engineer sits could use a leather tractor seat identical to the two we installed on the gas loco – Jan 5, 2026



The four batteries will be located under the driver and the toboggan seats, or on the loco. The centre of the car would have storage for batteries or compressor, like Dan's bench-eloco we used to use. The frame would be identical to the easy access car shown below one.



Dan's eLoco right



Controller:

*We may need to get a new controller for Little Toot suitable for 4 motors
(the Climax will need the P360 that we are now using on Little Toot)
... Jan 5, 2026*

It's arrived, under \$1000 with pst/gst collected

installation

https://www.youtube.com/watch?v=5ruKug_VU10

menus

https://www.youtube.com/watch?v=hu2BQqau_MU



Manual

https://www.4qd.co.uk/wp-content/uploads/Pro-360-controller-manual-v3_9.pdf

Contact Name Dave Florence

Item	Description	Quantity	Unit Price	Sub-Total
PRO-360-S	Pro-360 controller - standard [12-48V / 360A]	1	396.00	396.00
ISP-001	Interference suppression pack - extra motor	9	2.40	21.60
RBT-24V	Bell throttle, Reversing, 24v.	1	57.75	57.75
SEN-SPD	Speed sensor for Pro-160 / 360	1	26.95	26.95

Batteries – Lead-acid or gel batteries @24 volt will be stored in the follow-on car that has the tractor seat for the operator and toboggan seat for a few passengers behind. Lead acid or gel batteries provide lots of weight for the follow-on car, which has air brakes, so we will have good braking with or without passengers. *May want to use four @ 6-volt batteries Jan 5, 2026*



Load is 8 @ .18 hp motors (1.44 hp) , plus perhaps a ninth small motor for the drive shaft of the simulated Climax engines, plus soundcard, headlight and compressor for the air brakes

We looked at LiFePo4 batteries, but Facebook advisors and 4QD recommend 4x 12 volt lead acid unless space is the driving criteria. To accommodate space, we can put the batteries in the follow-on car, with the toboggan seat much like Dan’s eLoco that we use to pull the wheelchair car.

<https://www.facebook.com/groups/220852414703712/posts/7135279186594299>



Compressor

Maybe the model we just put into the gas loco is the best one to use – df, Jan 5, 2026

VEVOR make a 120 psi compressor; comes with a horn we could use to alert emergencies.

16.3 x 6.0 x 11.2 inch \$123 canadian

https://www.vevor.ca/train-horn-kit-c_11496/vevor-12v-air-compressor-with-tank-1-6-gallon-6-l-train-horn-air-compressor-120-psi-working-pressure-onboard-air-compressor-system-for-train-air-horns-inflating-tires-air-mattresses-p_010247980894



About this item

- Air Compressor 1.6-Gal Tank Kit: Our 12 volt air compressor with tank kit includes an air tank, compressor, and pipe set, reaching an efficient speed of 5000r/min. Provides stable air pressure quickly, ideal for air horns, tire inflation, air mattresses, and more, with minimal noise and damage risk.
- 90-120 psi Air Compressor: The train horn air compressor operates within a 90-120 psi range, with a sensitive gauge for real-time pressure monitoring. It automatically inflates at below 90 psi and stops at over 120 psi to prevent overpressure. The tank maintains optimal air pressure, enhanced with fuses for compressor protection and a drainage plug for easy water release.
- Strong Air Tightness: The air horn compressor is made from heavy-duty steel

with anti-rust coating, which is corrosion-resistant, impact-resistant, and wear-resistant. The air compressor features a non-leakage structure and a tightly welded air tank to minimize leakage risks.

- Shock Absorption and High-Temperature Resistance: The onboard air compressor kit includes a thick rubber cushion for noise reduction and enhanced stability when installed between the tank and vehicle bottom. The PA gas pipe withstands temperatures up to 120°C, and the motor is equipped with a 100°C temperature control overload protection, ensuring safe operation in various weather and road conditions.

- Universal 12V Compatibility: Our air compressor kit is designed for any vehicle with a 12V battery system, making it suitable for trucks, SUVs, cruise ships, and more. Its universal compatibility ensures ease of use without concerns about incompatibility

Sound System

Many sound card suppliers have gone out of business; there is no obvious supplier for logging railroad sound systems .. and perhaps even a smoke system! . Perhaps Wes Turnbull at PVRC could help find a source jan 5, 2026

Dan and 4QD recommend the Phoenix PB 17 sound card. \$US price 295.
the PB11 design to create the **BigSound™ PB17**.



It has the Climax steam engine as one of its sounds

<http://www.phoenixsound.com/products/pb17.html>

**BigSound™
PB17**

Released in January 2018, the BigSound™ PB17 is our standard does-it-all sound board. Perfect for DC, DCC, Remote Control and Ride On applications.

\$295.00 -
Complete
Kit

We'd need a 3 watt speaker too; two 8-ohm speakers recommended, or one 4 ohm.

e.g.

The Handbook http://www.phoenixsound.com/pdf/PB17_Handbook.pdf



SP-7140

DigiKey Part Number	433-1164-ND
Manufacturer	Soberton Inc.
Manufacturer Product Number	SP-7140
Description	SPEAKER 40HM 3W TOP PORT 85DB
Manufacturer Standard Lead Time	9 Weeks
Customer Reference	<input type="text"/>
Detailed Description	4 Ohms General Purpose Speaker 3 W 300 Hz ~ 20 kHz Top Rectangular
Datasheet	 Datasheet
EDA/CAD Models	SP-7140 Models

Image shown is a representation only. Exact specifications should be obtained from the product data sheet.

**Example speaker 4 cm x 7
cm \$11 + shipping**