

Building our Climax - Plan and Report

Paradise Valley Railroad, Powell River BC

As of Apr 15, 2024

Climax 50 ton 2-truck locomotive. At 2.25" scale

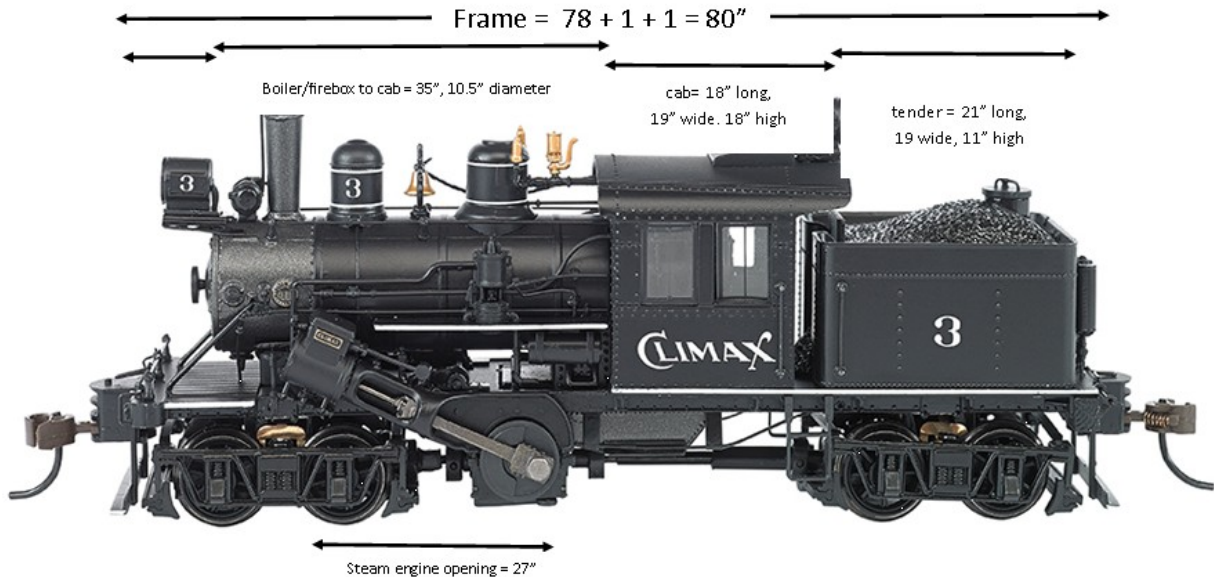

- we are basing our model on two sources:

- - the above photo of a small scale Climax. E.g., We'll likely use the straight boiler rather than the tapered one in Kozo's plan; and

- - the Kozo Hiraoka Climax book which describes a 3/4' scale model.

Our nominal dimensions are 3x of the Kozo plans to make ours a 2.25" = 12" model. On our 7.5" tracks it becomes a Narrow Gauge model.

- Dimensions will be adjusted to fit available material.

- We're not doing the skew-bevel gearing and drive shaft; (ie, we're after a Climax-like silhouette rather than an exact model). We're simply using two arch bar trucks with 5.5" wheels (by Tom Artzberger). (Wheels on this actual 50 ton Climax were 33", or 6.2" at our scale. wheels (would be 29.3" actual, more like freight car sized).)

Follow-on Pages:

Trucks, Frame, Cab, Boiler, Engines, Coal/Water tender, Follow-on Braked Operator/Passenger Car, Controller, Batteries, Compressor, Sound Card

Trucks



- Bought from Tom Artzberger.

Dave Florence picked them up and returned to PR March 2024.

Trucks are 14.5 wide, 20" long and 6"

Eight 24 volt Motors at 7.55 amps max = 0.18 hp each; = 1.5 hp total, torque for each =75 in. Oz

Dan is designing the bearing-connector to the bolster.

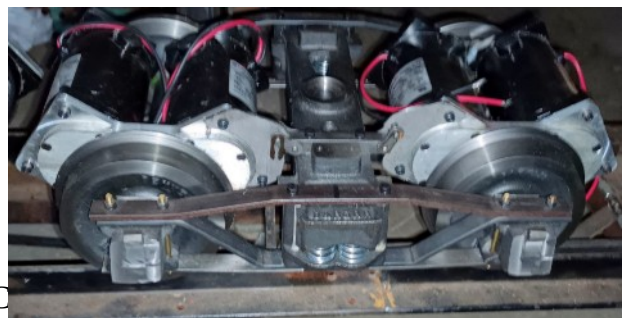
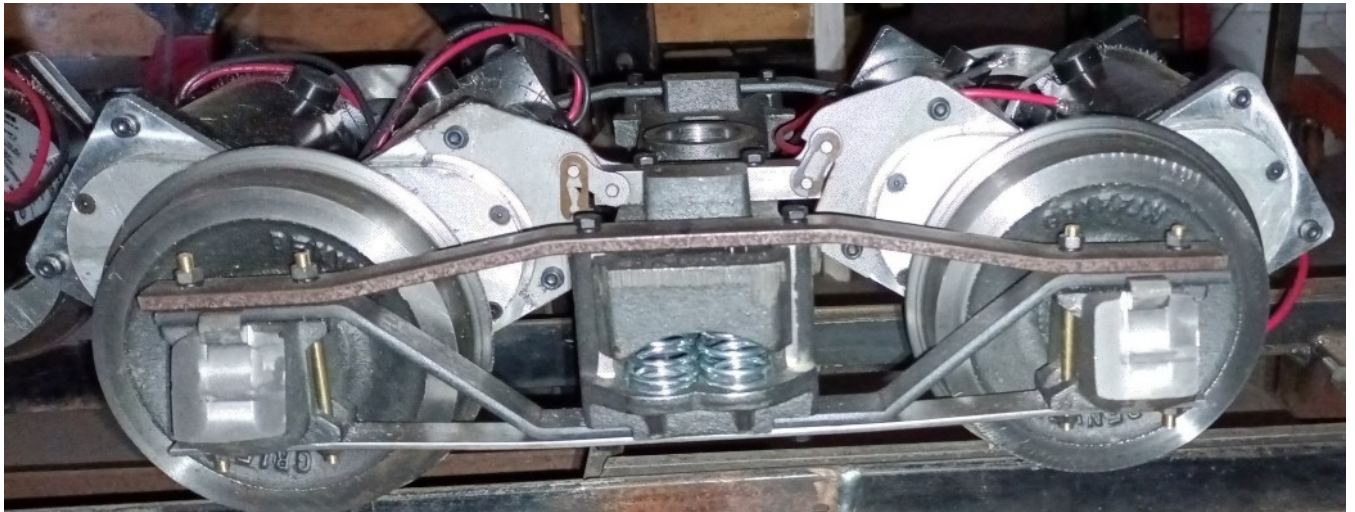

Frame, Bolsters and 3" Brackets

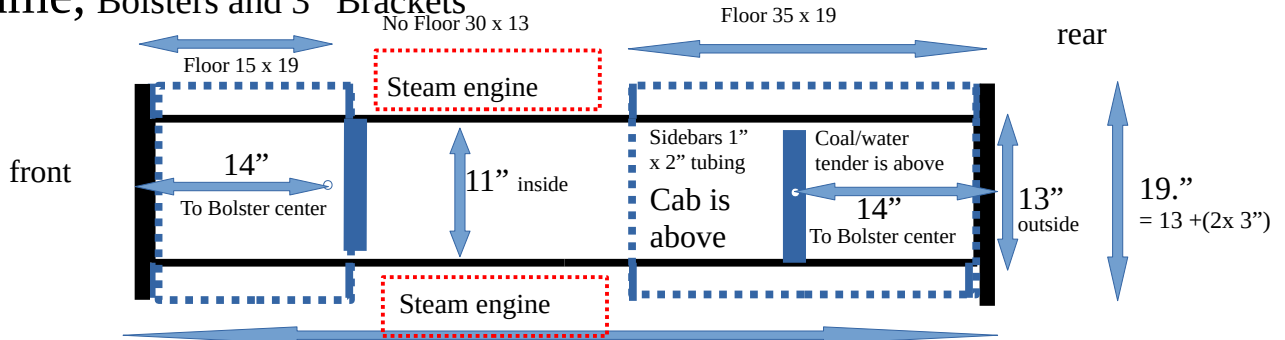

- 78" sidebar 1x2 tubing, two 1" x bumpers, 1.5" foot board at front and connector to pax car = 84" total
- The bumpers plus the 2 bolsters are 1"x 4" steel donated by Dan
- The 8 Brackets to extend the flooring wider are 3/4 x 2x 3.1" steel

The frame is a simple rectangle 13" wide with 3" supports at eight places each side for the floor plates (dotted line) that hang over the edge under the coal bin, cab, boiler etc, making it 19" wide. Bolster centres are 14" in from each end. Bumper bar and other bits hang off the ends making total length 84".

A floor is put on the frame under the water/coal bin, cab and part of the boiler, plus at the front, but omitted where the steam engine is outside the frame.

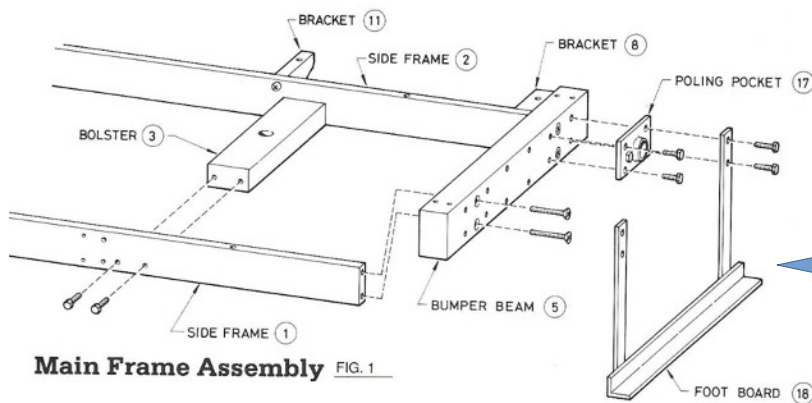

Bumper Beams and Bolsters are from a 1x4" steel piece that Dan is donating. Foot board are not yet designed

CAB

Until we build our own, Dan is planning to use one of his cabs temporarily

Dan's cab is 18" wide, 22 high, 14 long

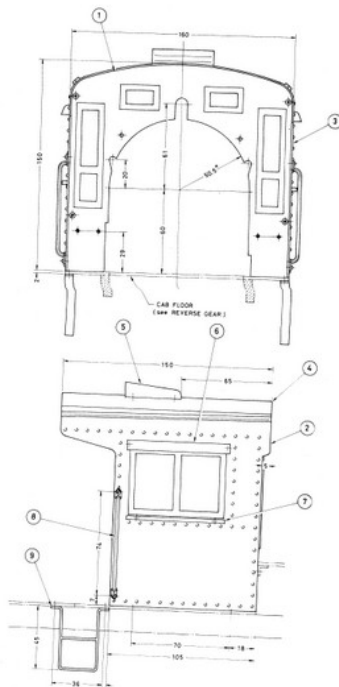

Our cab is 19" high and 18.4" wide (1/4" in from the full 19" width)

Dan plans to complete the measurements and contract out the sheet metal needed.

BOILER

The Kozo boiler is tapered – 10.6” diameter cylinder at the narrow end to 11.8” at the firebox end next to the cab, and 36” long.

If we go with a straight cylinder, it could be 10” or 12”, the most common cylinders available in either metal or as a cardboard concrete form.

Metal 36” x 10” pipe is costly - \$336 at Metal Supermarket Nanaimo.

Quikrete Building Forms 10 inch x 4 ft.

Model # 692202 | Store SKU # 1000133472

★★★★★ (49) | [Write a Review](#) [Q&A \(16\)](#)



1. To be economical, we could use a concrete form for \$15, cover it with stovepipe metal, and attach metal parts using a curved washer on the back for all the fastenings. And if we hate it, we could switch to metal later (ie, a useful prototype)

The Kozo Firebox is 10.5” wide, 12.5 long and about 14” useful space above for the compressor or tank (or one battery)

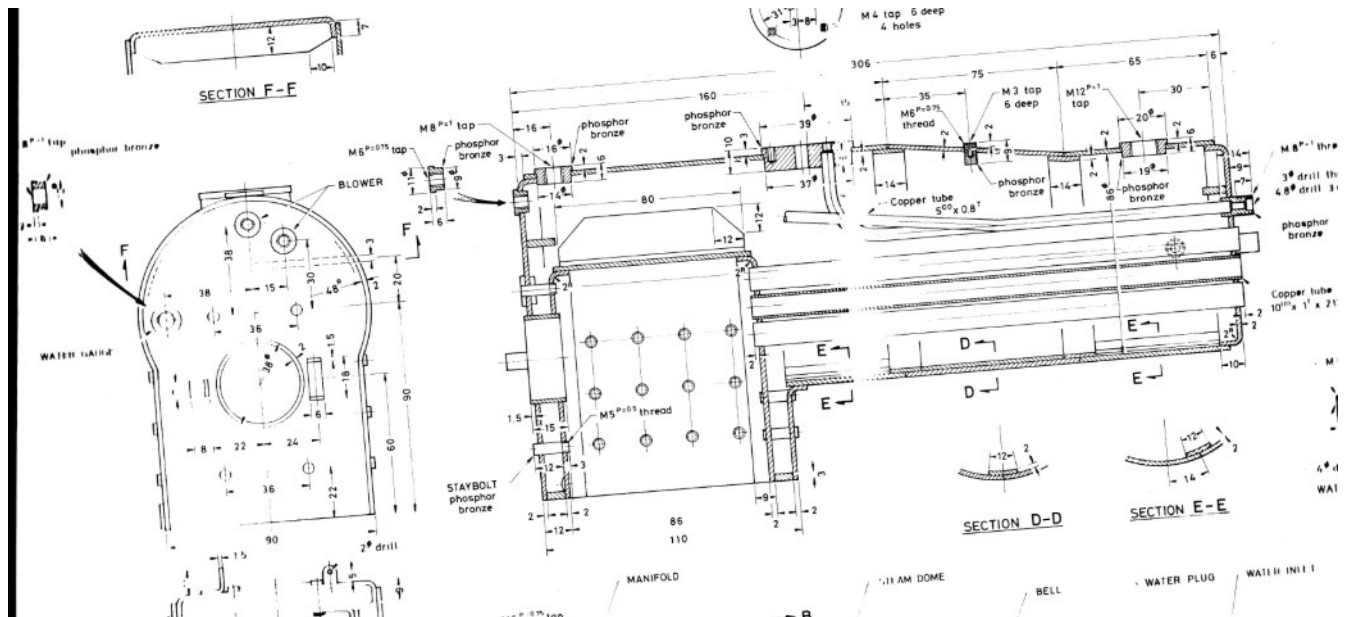

Engines



The defining feature of a Climax is the slanted engines, 22 degrees.

The idea is to have one on each side on a trans axel and power them with a small motor synchronized to the drive motors.

Dave built a model from wood and stovepipe metal. We need to complete the model, duplicate the mirror image, attach them to a trans-axel, and motorize the axel.

11 Engine

The engine of the Climax has a similar construction to that of the conventional rod locomotive, except that the cylinders are inclined at about twenty degrees. The elevation and top view in the assembly drawing show the right side assembly, the left side being opposite-handed.

In general, older Climax locos were equipped with Stephenson-type valve gear, and later ones with Walschaerts. As you see in the drawing, this Climax is designed with Walschaerts valve gear whose movements are more interesting to see. Each of the right and left engine

assemblies is bolted on the Main Frame and the Crankshaft Frame.

Material of the Cylinders (1) and (2) is copper-tin bronze, and the Pistons (14) are made of phosphor bronze. The groove in the Piston

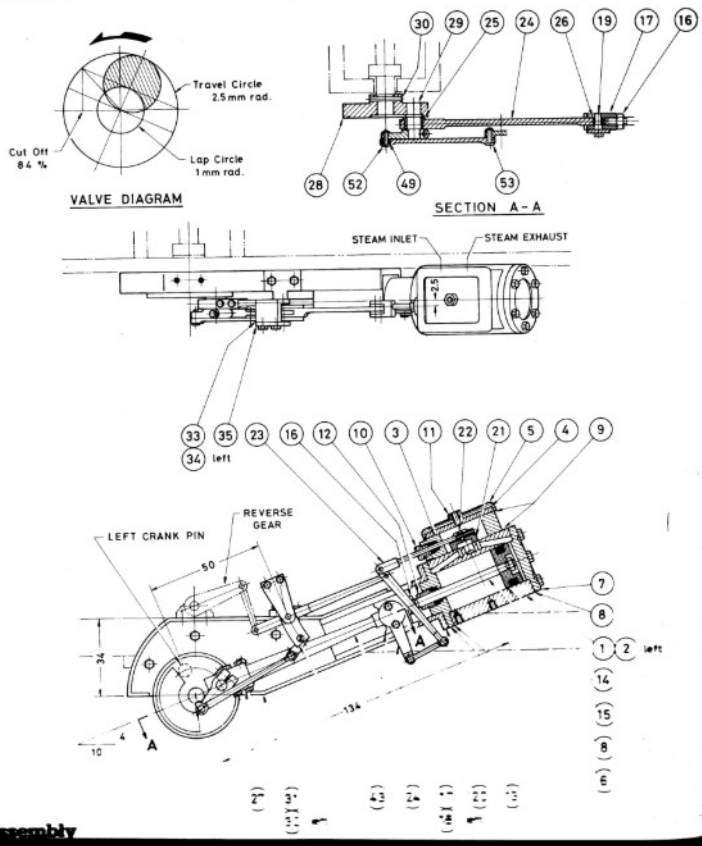

Engine Assembly

Coal/Water Tender

21" long, 18.5" wide and 11" high

Space in side can be used for a battery, or it could be made into a child seat
(not big enough for an operator seat (see Kozo drawing below))

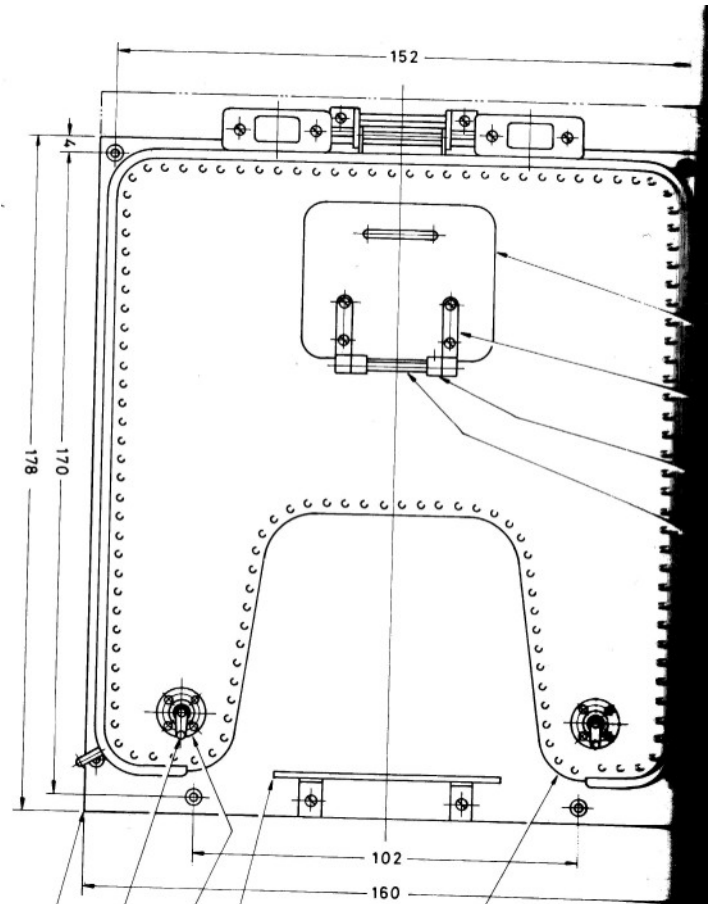
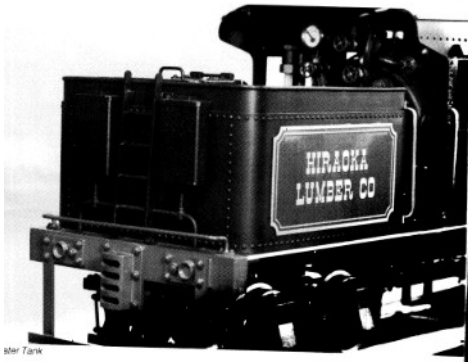

Follow on car

The idea is to combine a passenger car with operators car by using a tractor chair such as below with a toboggan seat behind like Dan's eloco that we use.

We bought two new air-braked trucks from Tom Artzberger.

We have four passenger cars now, the max without an on-board conductor, and probably our max tow capacity. So rather than build a new passenger car, one of our original passenger cars is likely ready for new trucks. We could rebuild the upper structure of that passenger car to include the operator's tractor chair at the front and room for two to four passengers behind on the toboggan seat that has batteries underneath, similar to Dan's eLoco.



Tractor seat left,

Dan's eLoco right



Controller:

4qd Pro-160 controller and accessories for under \$1000 canadian

Contact Name Dave Florence

Item	Description	Quantity	Unit Price	Sub-Total
PRO-360-S	Pro-360 controller - standard [12-48V / 360A]	1	396.00	396.00
ISP-001	Interference suppression pack - extra motor	9	2.40	21.60
RBT-24V	Bell throttle, Reversing, 24v.	1	57.75	57.75
SEN-SPD	Speed sensor for Pro-160 / 360	1	26.95	26.95

Batteries – Lead-acid or gel batteries @24 volt will be stored in the follow-on car that has the tractor seat for the operator and toboggan seat for a few passengers behind. Lead acid or gel batteries provide lots of weight for the follow-on car, which has air brakes, so we will have good braking with or without passengers.



Load is 8 @ .18 hp motors (1.44 hp) , plus perhaps a ninth small motor for the drive shaft of the simulated Climax engines, plus soundcard, headlight and compressor for the air brakes

We looked at LiFePo4 batteries, but Facebook advisors and 4QD recommend 4x 12 volt lead acid unless space is the driving criteria. To accommodate space, we can put the batteries in the follow-on car, with the toboggan seat much like Dan’s eLoco that we use to pull the wheelchair car.

<https://www.facebook.com/groups/220852414703712/posts/7135279186594299>



Compressor

VEVOR make a 120 psi compressor; comes with a horn we could use to alert emergencies.

16.3 x 6.0 x 11.2 inch \$123 canadian

https://www.vevor.ca/train-horn-kit-c_11496/vevor-12v-air-compressor-with-tank-1-6-gallon-6-l-train-horn-air-compressor-120-psi-working-pressure-onboard-air-compressor-system-for-train-air-horns-inflating-tires-air-mattresses-p_010247980894



About this item

- Air Compressor 1.6-Gal Tank Kit: Our 12 volt air compressor with tank kit includes an air tank, compressor, and pipe set, reaching an efficient speed of 5000r/min. Provides stable air pressure quickly, ideal for air horns, tire inflation, air mattresses, and more, with minimal noise and damage risk.
- 90-120 psi Air Compressor: The train horn air compressor operates within a 90-120 psi range, with a sensitive gauge for real-time pressure monitoring. It automatically inflates at below 90 psi and stops at over 120 psi to prevent overpressure. The tank maintains optimal air pressure, enhanced with fuses for compressor protection and a drainage plug for easy water release.
- Strong Air Tightness: The air horn compressor is made from heavy-duty steel

with anti-rust coating, which is corrosion-resistant, impact-resistant, and wear-resistant. The air compressor features a non-leakage structure and a tightly welded air tank to minimize leakage risks.

•Shock Absorption and High-Temperature Resistance: The onboard air compressor kit includes a thick rubber cushion for noise reduction and enhanced stability when installed between the tank and vehicle bottom. The PA gas pipe withstands temperatures up to 120°C, and the motor is equipped with a 100°C temperature control overload protection, ensuring safe operation in various weather and road conditions.

•Universal 12V Compatibility: Our air compressor kit is designed for any vehicle with a 12V battery system, making it suitable for trucks, SUVs, cruise ships, and more. Its universal compatibility ensures ease of use without concerns about incompatibility

Sound Card

Dan and 4QD recommend the Phoenix PB 17 sound card. \$US price 295.
the PB11 design to create the **BigSound™ PB17**.



It has the Climax steam engine as one of its sounds

<http://www.phoenixsound.com/products/pb17.html>

**BigSound™
PB17**

Released in January 2018, the BigSound™ PB17 is our standard does-it-all sound board. Perfect for DC, DCC, Remote Control and Ride On applications.

\$295.00 -
Complete
Kit

We'd need a 3 watt speaker too; two 8-ohm speakers recommended.

e.g.

The Handbook http://www.phoenixsound.com/pdf/PB17_Handbook.pdf



SP-7140

DigiKey Part Number	433-1164-ND
Manufacturer	Soberton Inc.
Manufacturer Product Number	SP-7140
Description	SPEAKER 40HM 3W TOP PORT 85DB
Manufacturer Standard Lead Time	9 Weeks
Customer Reference	<input type="text"/>
Detailed Description	4 Ohms General Purpose Speaker 3 W 300 Hz ~ 20 kHz Top Rectangular
Datasheet	 Datasheet
EDA/CAD Models	SP-7140 Models

Image shown is a representation only. Exact specifications should be obtained from the product data sheet.

Example speaker 4 cm x 7
cm \$11 + shipping